

Thermocouples Straight Design Model TC501, for Flue Gas Measurement

WIKA Data Sheet TE 65.30

Applications

- Blast furnaces, air heaters
- Red-heat and heat treatment processes
- Combustion of waste and special waste products
- Major heating plants, heat generation

Special Features

- Application ranges up to +1200 °C
- Thermowell made of heat resistant steel
- Measuring insert exchangeable
- Gastight process connection

Description

These straight thermocouples have a connection head form B. The thermowell is plugged into the connection head. Form 1 DIN-thermowells as well as thermowells with customer specific design are available.

Process connection is done via stop flange or pipe coupling, the latter type gives a gastight connection.

These temperature probes are suitable for gaseous media in low pressure ranges (up to approx. 1 bar). Various thermowell materials are used with or without enamelling to meet the requirements of thermal stress.

The exchangeable measuring insert can be dismantled. This makes inspection and, when servicing is necessary, replacement possible during operation and while the plant is running.

Selection of normal or standard lengths enables short delivery time and the possibility of stocking spare components.

Thermowell material, connection head and sensor can be selected individually for the respective application.

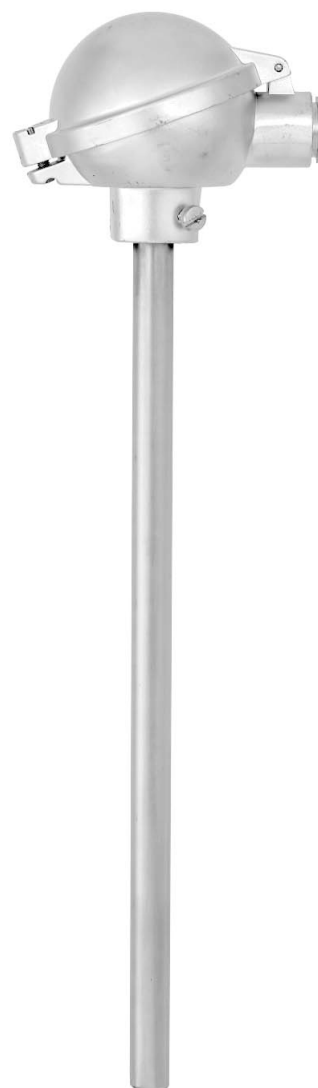

Thermocouple Straight Design, Model TC501

Optionally analogue or digital transmitters from the WIKA range can be fitted into the connection head of the TC501.

Sensor

Sensor types

Type	Recommended max. operating temperature
K (NiCr-Ni)	1200 °C
J (Fe-CuNi)	800 °C
E (NiCr-CuNi)	800 °C
T (Cu-CuNi)	400 °C
N (NiCrSi-NiSi)	1200 °C

In the case of type K there is a risk of blue mould forming between 850 °C and 950 °C. We recommend the use of a type N sensor, if the working temperature might be continuously within this range.

The application range of these thermometers is limited by the max. permissible temperature of the thermocouple as well as the max. temperature of the thermowell material.

Listed sensor types are available both as simplex or duplex thermocouples.

The measuring point (hot junction) of the probe is supplied as ungrounded unless specified otherwise.

Sensor limiting error

A cold junction temperature of 0 °C is taken as the basis for the definition of the sensor limiting error of thermocouples.

Type K

Class	Temperature range	Limiting error
DIN EN 60584 part 2		
1	-40 °C ... +375 °C	± 1.5 °C
1	+375 °C ... +1000 °C	± 0.0040 • t ¹⁾
2	-40 °C ... +333 °C	± 2.5 °C
2	+333 °C ... +1200 °C	± 0.0075 • t ¹⁾
ANSI MC96.1 (for information only, standard is cancelled)		
Standard	0 °C ... +1250 °C	± 2.2 °C or ²⁾ ± 0.75 %
Special	0 °C ... +1250 °C	± 1.1 °C or ²⁾ ± 0.4 %

Type J

Class	Temperature range	Limiting error
DIN EN 60584 part 2		
1	-40 °C ... +375 °C	± 1.5 °C
1	+375 °C ... +750 °C	± 0.0040 • t ¹⁾
2	-40 °C ... +333 °C	± 2.5 °C
2	+333 °C ... +750 °C	± 0.0075 • t ¹⁾
ANSI MC96.1 (for information only, standard is cancelled)		
Standard	0 °C ... +750 °C	± 2.2 °C or ²⁾ ± 0.75 %
Special	0 °C ... +750 °C	± 1.1 °C or ²⁾ ± 0.4 %

Type E

Class	Temperature range	Limiting error
DIN EN 60584 part 2		
1	-40 °C ... +375 °C	± 1.5 °C
1	+375 °C ... +800 °C	± 0.0040 • t ¹⁾
2	-40 °C ... +333 °C	± 2.5 °C
2	+333 °C ... +900 °C	± 0.0075 • t ¹⁾

Type T

Class	Temperature range	Limiting error
DIN EN 60584 part 2		
1	-40 °C ... +125 °C	± 0.5 °C
1	+125 °C ... +350 °C	± 0.0040 • t ¹⁾
2	-40 °C ... +133 °C	± 1.0 °C
2	+133 °C ... +350 °C	± 0.0075 • t ¹⁾

Type N

Class	Temperature range	Limiting error
DIN EN 60584 part 2		
1	-40 °C ... +375 °C	± 1.5 °C
1	+375 °C ... +1000 °C	± 0.0040 • t ¹⁾
2	-40 °C ... +333 °C	± 2.5 °C
2	+333 °C ... +1200 °C	± 0.0075 • t ¹⁾

1) |t| is the value of the temperature in °C without consideration of the sign
2) Whichever is larger.

Limiting error with selected temperatures in °C for thermocouples type K and type J

Temperature (ITS 90) °C	Limiting error DIN EN 60584	
	Class 1 °C	Class 2 °C
0	± 1.5	± 2.5
100	± 1.5	± 2.5
200	± 1.5	± 2.5
300	± 1.5	± 2.5
400	± 1.6	± 3
500	± 2	± 3.75
600	± 2.4	± 4.5
700	± 2.8	± 5.25
800	± 3.2	± 6
900	± 3.6	± 6.75
1000	± 4	± 7.5
1100	± 4.4	± 8.25
1200	± 4.8	± 9

Precious metal thermocouples Types R, S and B on request

TC501 components

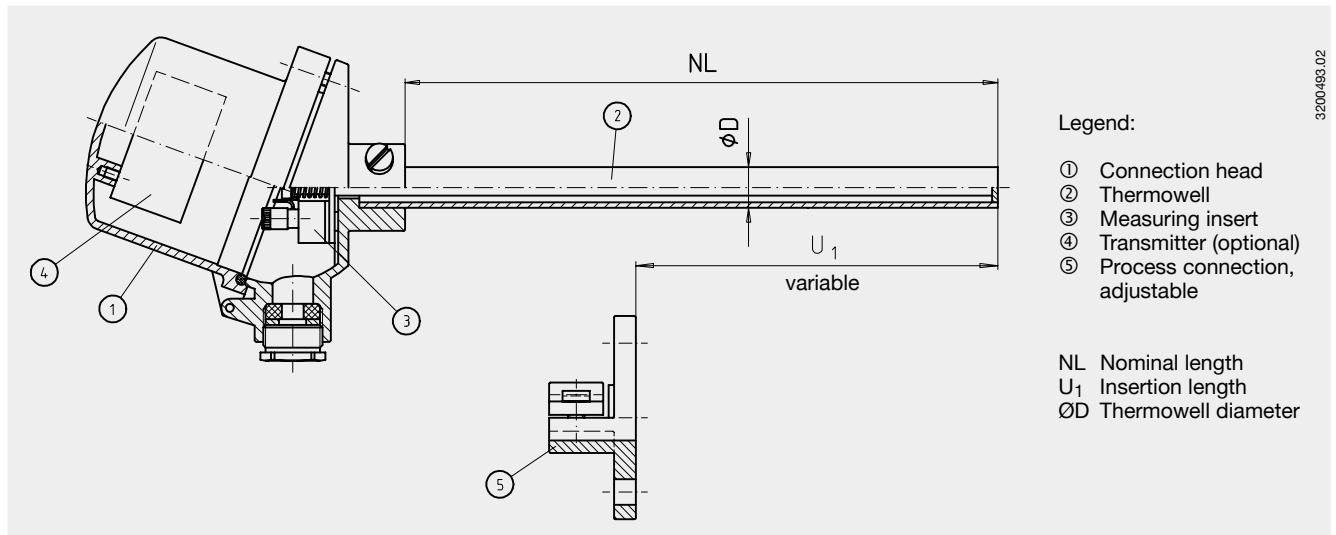

Connection head

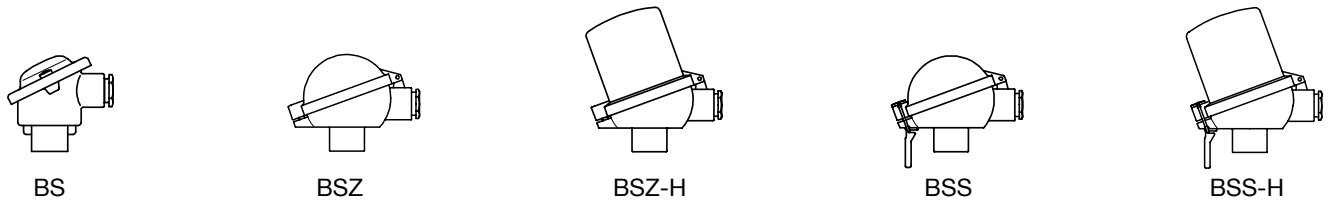

Model	Material	Cable entry	Ingress protection	Cap	Surface finish
BS	aluminium	M20 x 1.5	IP53	cap with 2 screws	silver bronze, painted
BSZ	aluminium	M20 x 1.5	IP53	flap cap with screw	silver bronze, painted
BSZ-H	aluminium	M20 x 1.5	IP53	flap cap with screw	silver bronze, painted
BSS	aluminium	M20 x 1.5	IP53	flap cap with clip	silver bronze, painted
BSS-H	aluminium	M20 x 1.5	IP53	flap cap with clip	silver bronze, painted

Transmitter (option)

Depending on used connection head a transmitter can be mounted into the thermometer (head mount).

- mounted instead of connection socket
- mounted within the cap of the connection head
- mounting not possible

Mounting of two transmitters on request.

Connection head	Transmitter				
	T12	T19	T32	T42	T5350
BS	–	○	–	–	–
BSZ	○	○	○	○	○
BSZ-H	●	●	●	●	●
BSS	○	○	○	○	○
BSS-H	●	●	●	●	●

Model	Description	Data sheet
T19	Analogue transmitter, configurable	TE 19.01
T12	Digital transmitter, PC configurable	TE 12.01
T32	Digital transmitter, HART protocol	TE 32.01
T42	Digital transmitter, PROFIBUS PA	TE 42.01
T5350	Digital transmitter FOUNDATION Fieldbus and PROFIBUS PA	TE 53.01

Thermowell

The thermowells are made of tube. The bottom of the thermowell is either flat or dished (technically equivalent), in the case of enamelled thermowells it is always dished. The thermowell is plugged into the connection head and compression fitted. The slideable process connection is compression fitted on the thermowell, thus allowing a variable insertion length. Preference is to be given to standard nominal lengths to DIN Standards.

Designs to DIN Standards as well as special designs (for example, with tapered thermowell, etc.) are available in standard or special materials.

Material of thermowell

- Carbon steel 1.0305
up to 550 °C (air), low corrosion resistance to sulphurous gases, medium corrosion resistance to nitrogenous gases
 - Carbon steel 1.0305, enamelled
up to 550 °C, resistant to a max. applied pressure of 1 bar, for the low pressure range in furnaces and flue gas ducts
 - Stainless steel 1.4571
up to 700 °C (air), good corrosion resistance to aggressive media
 - Stainless steel 1.4841
up to 1150 °C (air), low corrosion resistance to sulphurous gases; high corrosion resistance to nitrogenous gases and gases with low oxygen content; high long-time rupture strength
 - Stainless steel 1.4762
up to 1200 °C (air), high corrosion resistance to sulphurous gases; low corrosion resistance to nitrogenous gases
 - Stainless steel 1.4749
up to 1100 °C (air), very high corrosion resistance to sulphurous gases; low corrosion resistance to nitrogenous gases, good corrosion resistance to lead and tin melting
- other materials on request

Nominal lengths

500, 710, 1000 and 1400 mm,
other lengths on request

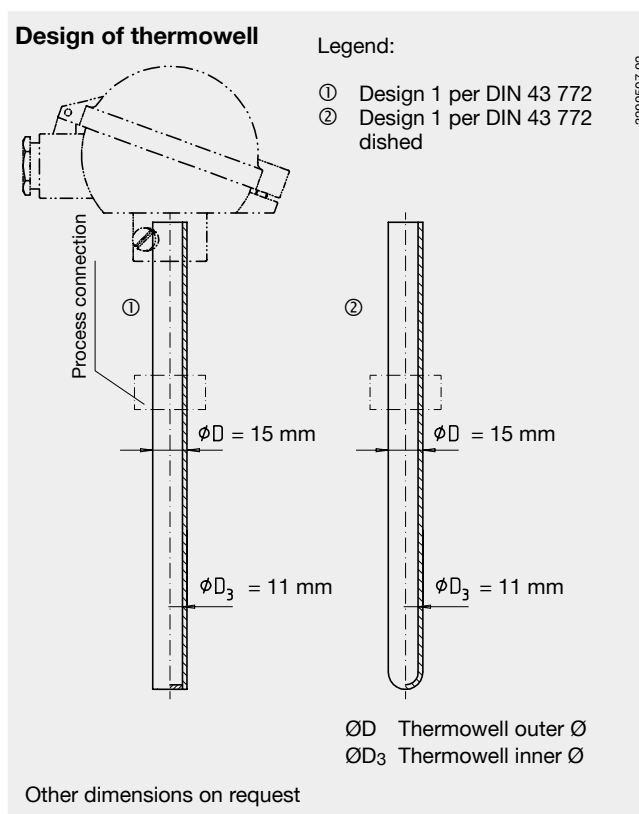

Process connection

Stop flange (also with mating flange) or pipe coupling are used as the process connection. For enamelled thermowells the pipe coupling is to be used to prevent the enamel layer from being damaged.

Both versions are slideable on the thermowell. Therefore, the insertion length of the thermometer is variable and can

be easily adapted at the installation point.

For applications in which a gastight process connection is not required, a stop flange is sufficient. A gastight process connection up to 1 bar is provided by a pipe coupling or a combination of stop flange and mating flange.

Pipe coupling
adjustable, gastight up to 1 bar
Seal: asbestos free

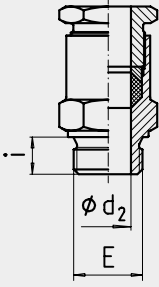

3163067.02

Material:
carbon steel
other materials on request

Thread:
G 1/2 or G 3/4
other threads on request

Dimensions:
 ϕd_2 min. 15.5 mm
i min. 16 mm

Stop flange DIN 43 734
adjustable

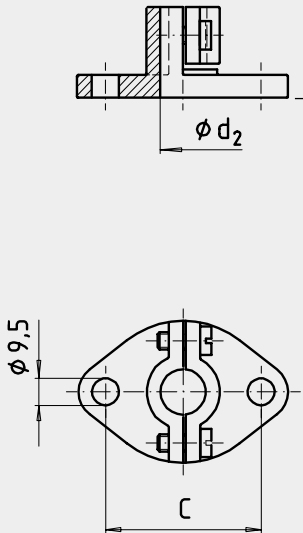

3163059.02

Material:
malleable cast iron

Mating flange DIN 43 734
gastight up to 1 bar
Seal: asbestos free

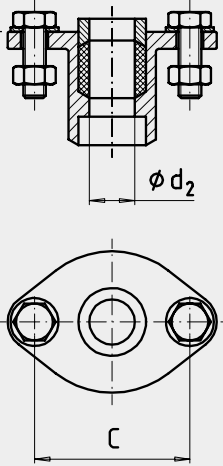

Dimensions:
 ϕd_2 16 mm (stop flange)
 ϕd_2 17 mm (mating flange)
C 55 mm

Measuring insert

The measuring insert is made of a vibration-resistant sheathed measuring cable (MI cable). In order to ensure that the measuring insert is firmly pressed down on the thermowell bottom the insert is spring-loaded (spring travel: max 10 mm). The standard material used for the measuring insert sheath is Inconel.

Electrical connection

Simplex thermocouple

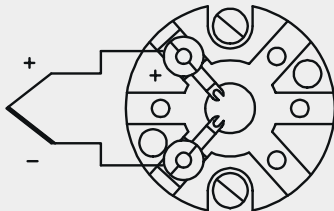

Duplex thermocouple

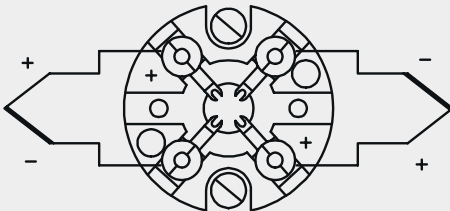

The colour coding at the positive pole of the device always decide the correlation of polarity and connection terminal.

3166822.03

Ordering information

Field No.	Code	Features
		Type and number of sensors
	A	1 x type K (NiCr-Ni)
	B	2 x type K (NiCr-Ni) ¹⁾
	C	1 x type J (Fe-CuNi)
	D	2 x type J (Fe-CuNi) ¹⁾
1	[]	? other <i>please state as additional text</i>
		Sensor limiting error
	2	class 2 per DIN EN 60 584
	1	class 1 per DIN EN 60 584
	8	ISA (ANSI) standard to MC96.1-1982
	9	ISA (ANSI) special to MC96.1-1982
2	[]	? other <i>please state as additional text</i>
		Measuring point
	1	insulated
3	[]	2 not insulated
		Process connection
	ZZ	without
	P1	pipe coupling G 1/2, carbon steel <i>adjustable</i>
	P2	pipe coupling G 3/4, carbon steel <i>adjustable</i>
	A1	stop flange DIN 43734, malleable cast iron <i>adjustable</i>
	A5	stop flange with mating flange DIN 43734, malleable cast iron <i>adjustable</i>
4	[]	?? other <i>please state as additional text</i>
		Thermowell outer diameter
	8	15 mm <i>metal</i>
5	[]	? other <i>please state as additional text</i>
		Thermowell material
	B	carbon steel 1.0305
	C	carbon steel 1.0305, enamelled
	1	stainless steel 1.4571
6	[]	? other <i>please state as additional text</i>
		Nominal length
	0500	500 mm
	0710	710 mm
	1000	1000 mm
	1400	1400 mm
7	[]	length in mm, e.g. 0850 for 850 mm
		Connection head
	1	model BS (aluminium) <i>mounting of a transmitter not possible (thermal reasons)</i>
	2	model BSZ (aluminium) <i>mounting of a transmitter not possible (thermal reasons)</i>
	3	model BSZ-H (aluminium) <i>mounting of an optional transmitter in the cap possible</i>
	4	model BSS (aluminium) <i>mounting of a transmitter not possible (thermal reasons)</i>
	5	model BSS-H (aluminium) <i>mounting of an optional transmitter in the cap possible</i>
8	[]	? other <i>please state as additional text</i>
		Cable entry to connection head
	4	M20 x 1.5
9	[]	? other <i>please state as additional text</i>
		Transmitter
	ZZ	without
	TA	mounted on the measuring insert
10	[]	TB mounted in the cap of the connection head
		Additional order info
	YES	NO
11	[]	T Z quality certificates <i>see price list</i>
12	[]	T Z additional text <i>Please state as clearly understandable text!</i>

1) Duplex thermocouple in combination with 2 transmitters on request

Order code:

TC501	-	Z	-	1	2	3	-	4	-	5	6	7	8	9	10	ZZ	-	11	12

Additional text: _____

Specifications and dimensions given in this leaflet represent the state of engineering at the time of printing.
Modifications may take place and materials specified may be replaced by others without prior notice.



WIKAI Alexander Wiegand GmbH & Co. KG
Alexander-Wiegand-Straße 30
63911 Klingenberg/Germany
Phone (+49) 93 72/132-0
Fax (+49) 93 72/132-406
E-Mail info@wika.de
www.wika.de